

REMOVAL

1. DISCONNECT CABLE FROM NEGATIVE BATTERY TERMINAL
2. REMOVE BACK DOOR TRIM COVER RH (See page ED-48)
3. REMOVE BACK DOOR TRIM COVER LH (See page ED-48)
4. REMOVE DOOR TRIM RETAINER CAP (See page ED-48)
5. REMOVE BACK DOOR TRIM BOARD (See page ED-49)
6. REMOVE BACK DOOR SERVICE HOLE COVER (See page ED-49)
7. REMOVE REAR WIPER ARM AND BLADE ASSEMBLY

(a) Open the rear wiper arm head cap.

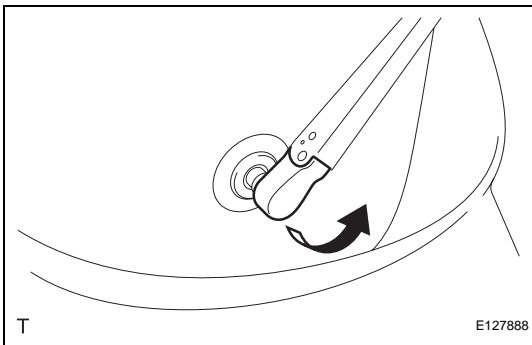

(b) Remove the nut and the rear wiper arm and blade.

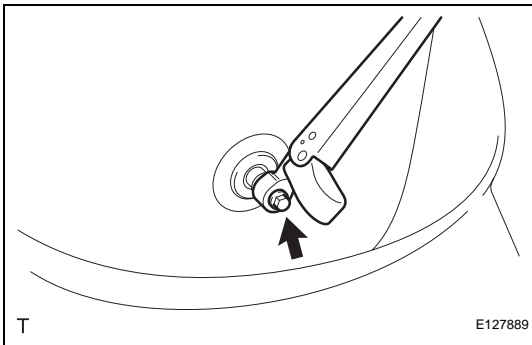

8. REMOVE REAR WIPER MOTOR

(a) Disconnect the connector.
 (b) Remove 3 bolts and the rear wiper motor.

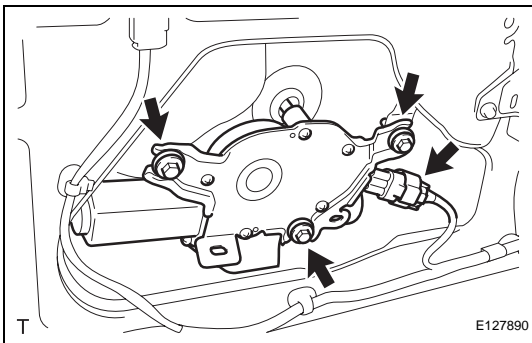

WW

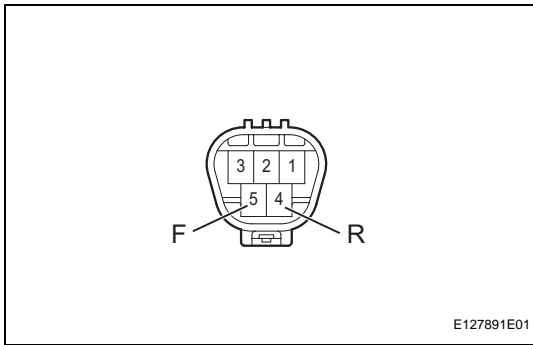

INSPECTION

1. INSPECT REAR WIPER MOTOR

- (a) Check the operation.
 - (1) Connect the positive battery (+) lead to terminal 5 (F) and the negative battery (-) lead to terminal 4 (R), and check that the rear wiper motor operates.

Standard:

The rear wiper motor operates.

NOTICE:

Check that the body ground is connected.

If the result is not as specified, replace the motor.

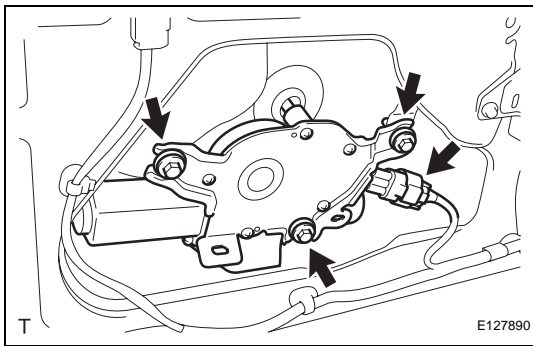

INSTALLATION

1. INSTALL REAR WIPER MOTOR

- (a) Install the rear wiper motor with the 3 bolts.

Torque: 5.5 N*m (56 kgf*cm, 49 in.*lbf)
- (b) Connect the connector.

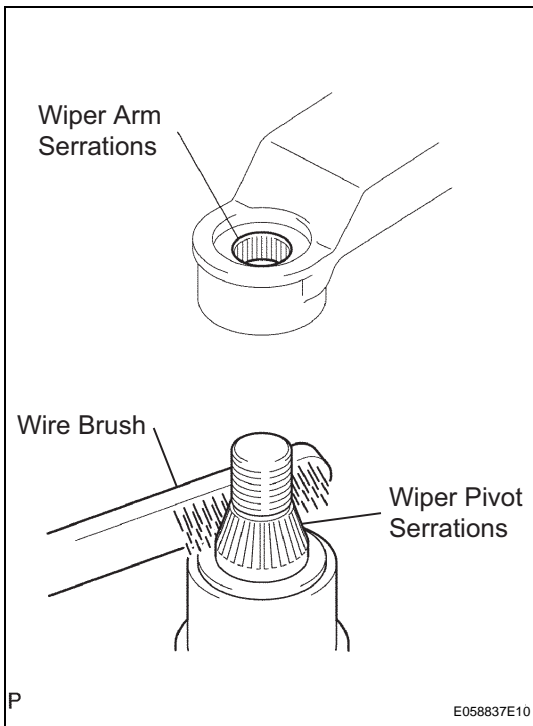

2. INSTALL REAR WIPER ARM AND BLADE ASSEMBLY

- (a) Scrape any metal powder off the serrated part of the wiper arm with a round file or the equivalent (when reinstalling).
- (b) Clean the wiper pivot serrations with a wire brush.
- (c) Operate the wiper, then stop the windshield wiper motor in the automatic stop position.

WW

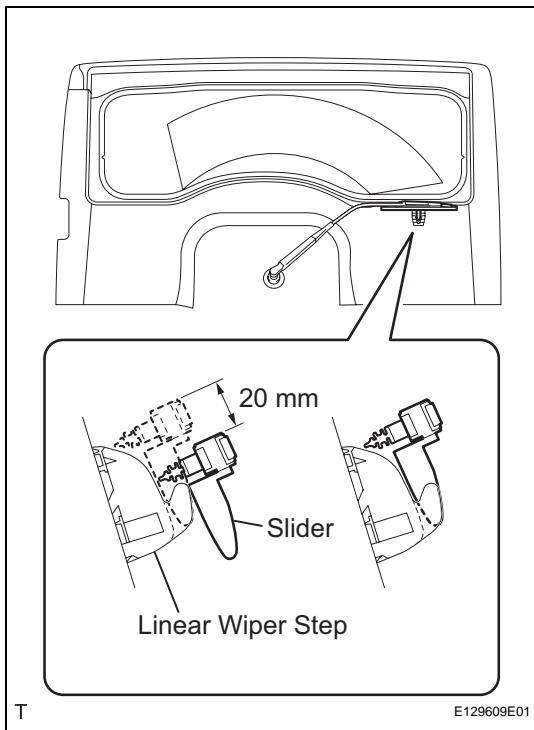

- (d) Install the rear wiper arm in the position shown in the illustration with the nut.

Torque: 5.5 N*m (56 kgf*cm, 49 in.*lbf)

HINT:

Using the nut, Tighten the rear wiper arm with the slider on the linear wiper step, 20 mm below the rise-up position in the rotational direction.

- (e) Return the slider to the rise-up position.

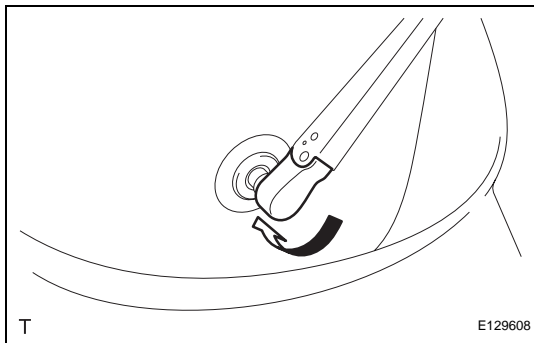

- (f) Close the rear wiper arm head cap.

3. **INSTALL BACK DOOR SERVICE HOLE COVER (See page ED-56)**
4. **INSTALL BACK DOOR TRIM BOARD (See page ED-57)**
5. **INSTALL DOOR TRIM RETAINER CAP (See page ED-57)**
6. **INSTALL BACK DOOR TRIM COVER LH (See page ED-57)**
7. **INSTALL BACK DOOR TRIM COVER RH (See page ED-57)**
8. **CONNECT CABLE TO NEGATIVE BATTERY TERMINAL**
Torque: 3.9 N*m (40 kgf*cm, 35 in.*lbf)

WW