

PARKING BRAKE ASSEMBLY

COMPONENTS

PB

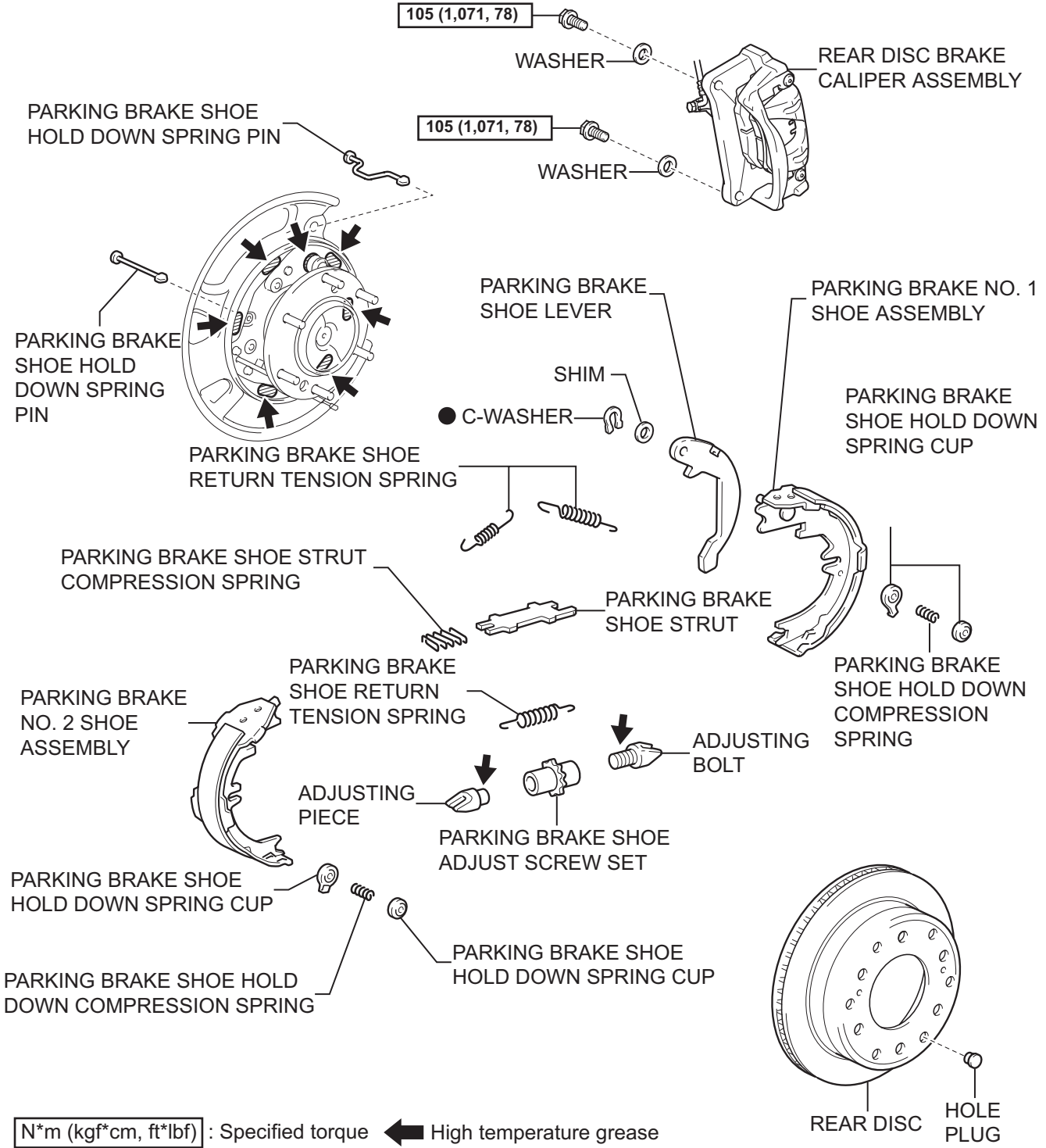

N*m (kgf*cm, ft*lbf) : Specified torque ← High temperature grease

● Non-reusable part

REMOVAL

1. REMOVE REAR WHEEL
2. SEPARATE REAR DISC BRAKE CALIPER ASSEMBLY

(a) Remove the 2 bolts and 2 washers and separate the disc brake caliper assembly.

NOTICE:

Suspend the disc brake caliper assembly with a piece of rope.

3. REMOVE REAR DISC

(a) Release the parking brake lever.

(b) Place matchmarks on the disc and axle hub and remove the disc.

HINT:

If the disc cannot be removed easily, turn the shoe adjuster until the wheel turns freely.

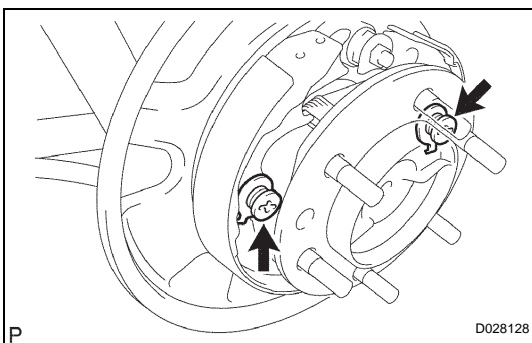
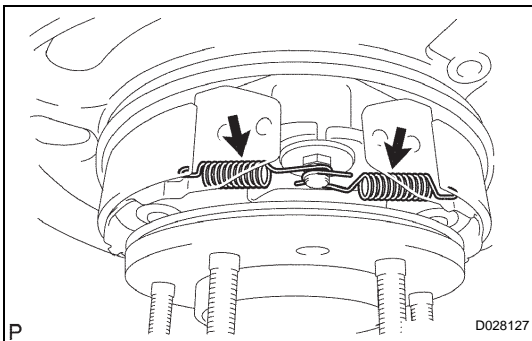
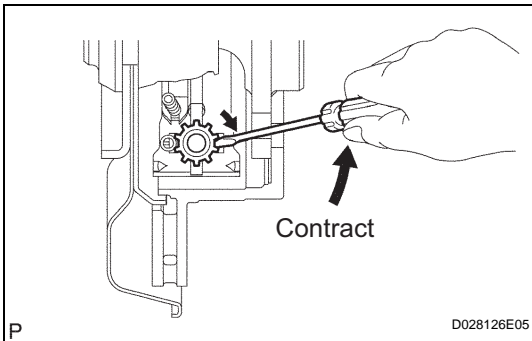
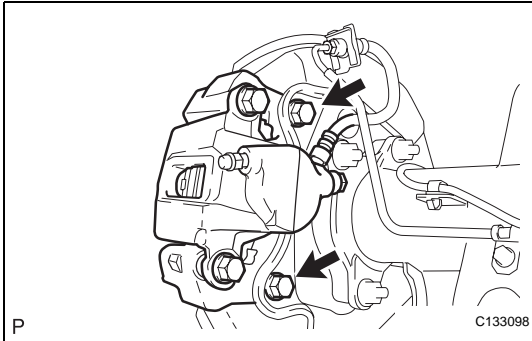

DISASSEMBLY

1. REMOVE PARKING BRAKE SHOE RETURN TENSION SPRING

(a) Using needle-nose pliers, remove the 2 return tension springs.

2. REMOVE PARKING BRAKE SHOE STRUT

(a) Remove the parking brake shoe strut and compression spring.

3. REMOVE PARKING BRAKE SHOE

(a) Remove the 2 hold down spring cups, hold down compression spring and hold down spring pin.

(b) Disconnect the return tension spring and remove the No. 2 shoe.

(c) Remove the shoe adjusting screw set and return tension spring.

(d) Remove the 2 hold down spring cups, hold down compression spring and hold down spring pin.

(e) Using needle-nose pliers, disconnect the parking brake cable and remove the No. 1 shoe.

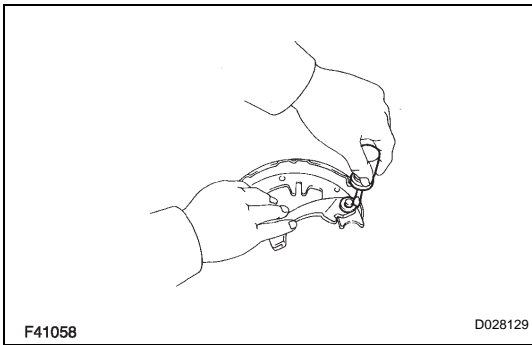

4. REMOVE PARKING BRAKE SHOE LEVER

- (a) Using a screwdriver, remove the C-washer.
- (b) Remove the shim and parking brake shoe lever from the No. 1 shoe.

PB

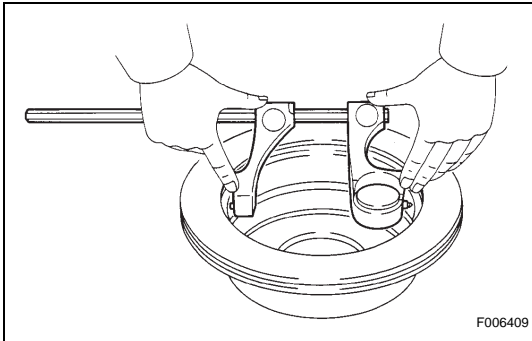

INSPECTION

1. INSPECT BRAKE DISC INSIDE DIAMETER

- (a) Using a brake drum gauge or the equivalent, measure the inside diameter of the rear disc.

Standard inside diameter:

210 mm (8.268 in.)

Maximum inside diameter:

211 mm (8.307 in.)

If the inside diameter is greater than the maximum, replace the rear disc.

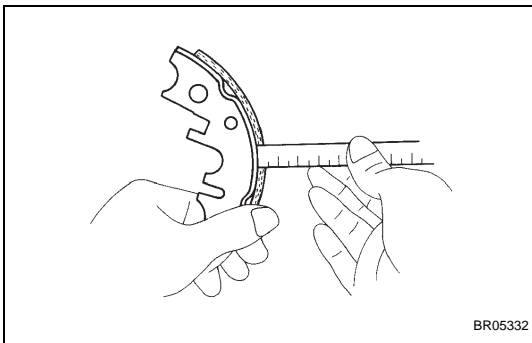

2. INSPECT PARKING BRAKE SHOE LINING THICKNESS

- (a) Using a ruler, measure the thickness of the shoe lining.

Standard thickness:

4.0 mm (0.157 in.)

Minimum thickness:

1.0 mm (0.039 in.)

If the lining thickness is equal to or less than the minimum value, or if there is any severe or uneven wear, replace the brake shoe.

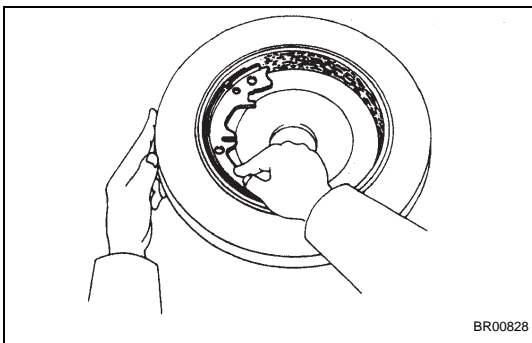

3. INSPECT BRAKE DISC AND PARKING BRAKE SHOE LINING FOR PROPER CONTACT

- (a) Apply chalk to the inside surface of the disc, then grind the brake shoe lining so that they fit together properly.

If the contact between the disc and the shoe lining is improper, repair it using a brake shoe grinder or replace the brake shoe assembly.

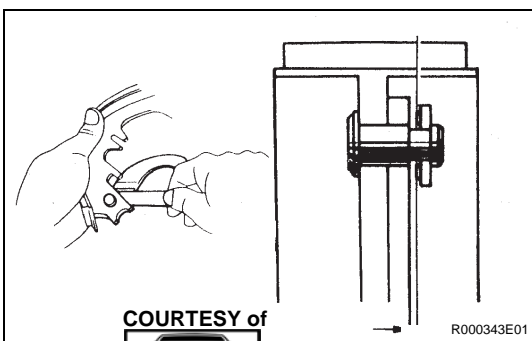

REASSEMBLY

1. INSTALL PARKING BRAKE SHOE LEVER

- (a) Using a feeler gauge, measure the clearance.

Standard clearance:

Less than 0.25 mm (0.0098 in.)

If the clearance is not within the specifications, replace the shim with one of the correct size.

Part No.	Shim Thickness
90564-09184	0.3 mm (0.012 in.)
90564-09002	0.4 mm (0.016 in.)

COURTESY of



Part No.	Shim Thickness
90564-09003	0.5 mm (0.020 in.)
90564-09185	0.6 mm (0.024 in.)
90564-09186	0.9 mm (0.035 in.)

- (b) Using pliers, install the parking brake shoe lever and the shim with a new C-washer.

2. APPLY HIGH TEMPERATURE GREASE

- (a) Apply high temperature grease to the surface of the backing plate which is in contact with the shoe.

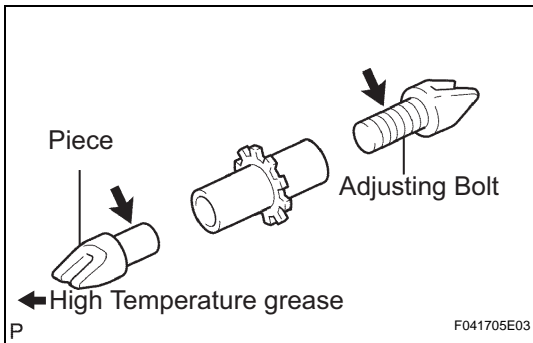

3. INSTALL PARKING BRAKE SHOE

- (a) Apply high temperature grease to the adjusting bolt and piece.
- (b) Using needle-nose pliers, connect the parking brake cable to the parking brake shoe lever.

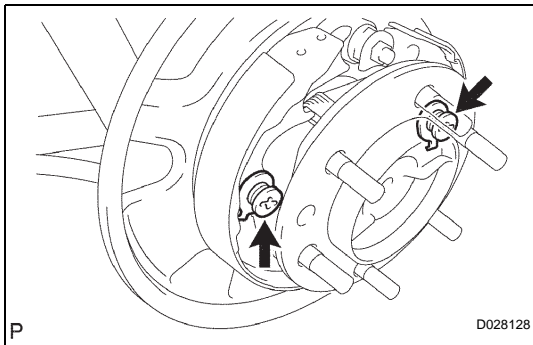

- (c) Install the No. 1 shoe, hold down spring pin, hold down compression spring and 2 hold down spring cups.
- (d) Install the return tension spring and shoe adjusting screw set.
- (e) Install the No. 2 shoe, hold down spring pin, hold down compression spring and 2 hold down spring cups.

4. INSTALL PARKING BRAKE SHOE STRUT

- (a) Attach the compression spring and parking brake shoe strut to the No. 2 and No. 1 shoes.

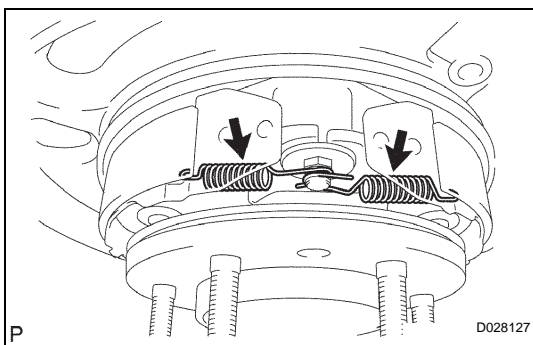

5. INSTALL PARKING BRAKE SHOE RETURN TENSION SPRING

- (a) Using needle-nose pliers, install the 2 return tension springs.
HINT:
 First install the front side spring then install the rear side spring.

PB

6. CHECK PARKING BRAKE INSTALLATION
(a) Check that each part is installed properly.

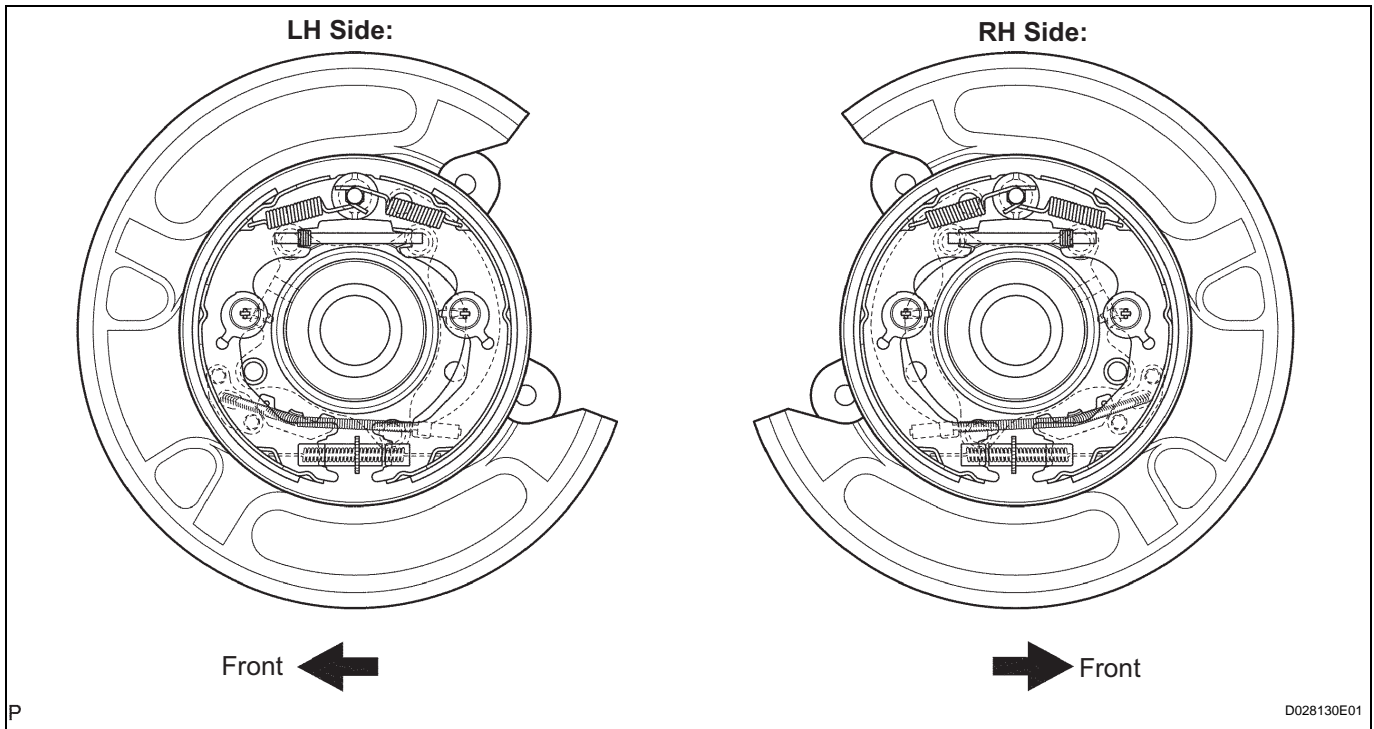

NOTICE:
There should be no oil or grease adhering to the friction surfaces of the shoe lining or the disc.