

INSPECTION

1. INSPECT BRAKE BOOSTER PUMP ASSEMBLY

- Connect the positive (+) lead from the battery to the red cable of the pump, and the negative (-) lead to the black cable.
- Check the brake booster pump operation.

OK:

Operation sound is heard.

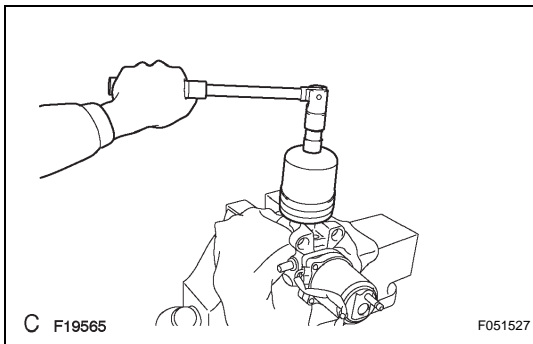

REASSEMBLY

1. INSTALL BRAKE BOOSTER ACCUMULATOR ASSEMBLY

- Place the brake booster pump in a vise lined with a cloth.
- Install the brake booster accumulator pipe, compression spring and a new O-ring.

NOTICE:

Ensure that no foreign matter enters the pump.

- Install the brake booster accumulator onto the brake booster pump.

Torque: 57 N*m (585 kgf*cm, 42 ft.*lbf)

2. INSTALL PISTON

- Apply lithium soap base glycol grease to a new piston.
- Install the piston into the master cylinder body.
- Using 2 screwdrivers, install a new C-ring while pressing the piston.

NOTICE:

Do not damage the rubber lips on the piston when reassembling.

3. INSTALL MASTER CYLINDER BOOT

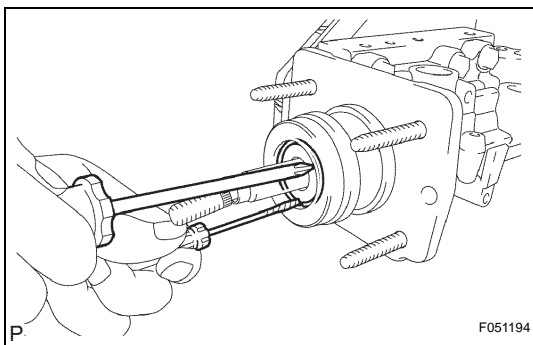

4. INSTALL MASTER CYLINDER PUSH ROD CLEVIS

- Install the master cylinder side lock nut and rod operating adapter.

Torque: 26 N*m (260 kgf*cm, 19 ft.*lbf)

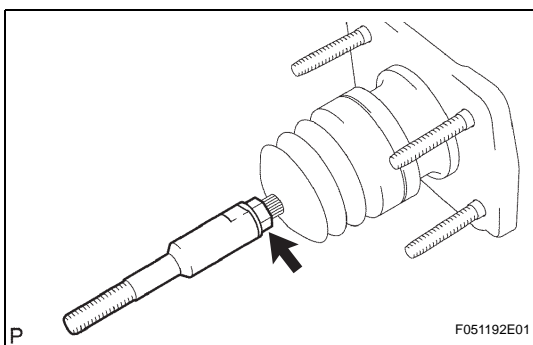

COURTESY of



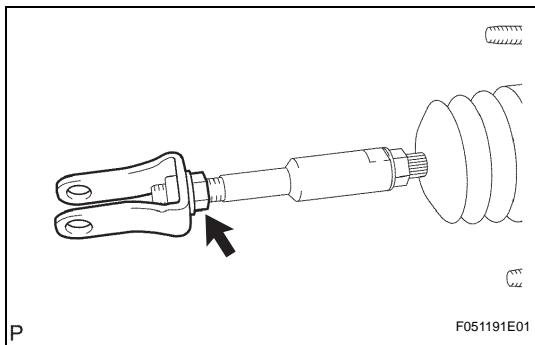

- (b) Install the lock nut and push rod clevis.
Torque: 26 N*m (260 kgf*cm, 19 ft.*lbf)

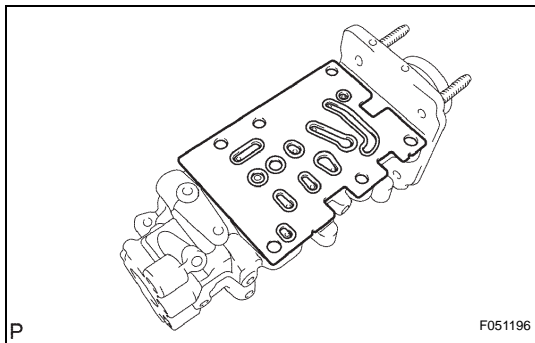

5. INSTALL MASTER CYLINDER SOLENOID

- (a) Place a new gasket onto the master cylinder solenoid.

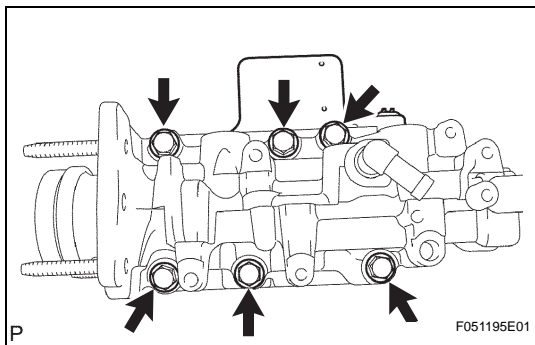

- (b) Install the master cylinder solenoid with 6 new bolts.
Torque: 32 N*m (325 kgf*cm, 24 ft.*lbf)

NOTICE:

Do not let water, dust, or other foreign matter adhere to the surface or fitting surfaces of the master cylinder solenoid, master cylinder body and gasket.

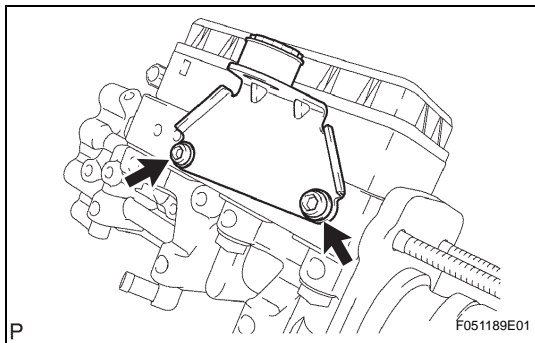

6. INSTALL BRAKE BOOSTER PUMP BRACKET

- (a) Using a 5 mm hexagon wrench, install the brake booster pump bracket with the 2 bolts.
Torque: 7.8 N*m (80 kgf*cm, 69 in.*lbf)
- (b) Install the bush onto the brake booster pump bracket.

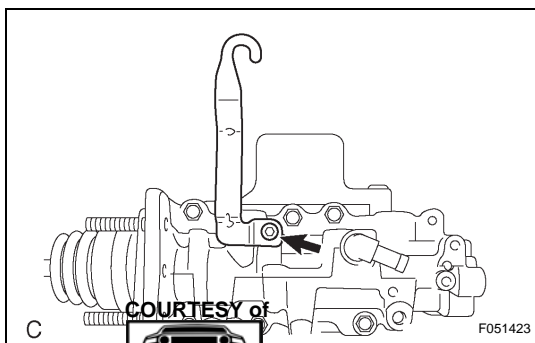

7. INSTALL BRAKE ACTUATOR BRACKET

- (a) Using a 5 mm hexagon wrench, install the brake actuator bracket with the bolt.
Torque: 7.8 N*m (80 kgf*cm, 69 in.*lbf)

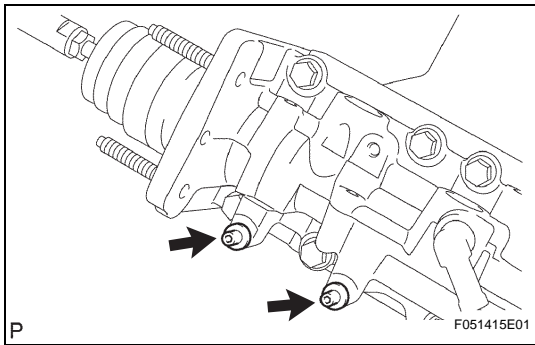

8. INSTALL BRAKE BOOSTER WITH ACCUMULATOR PUMP ASSEMBLY

- (a) Using a 4 mm hexagon wrench, install the 2 pins.
Torque: 7.8 N*m (80 kgf*cm, 69 in.*lbf)
- (b) Install the 2 collars and 2 bushes onto the brake booster with accumulator pump assembly.

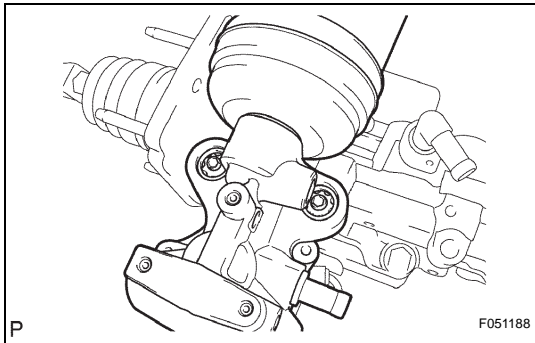

- (c) Install the brake booster with accumulator pump assembly.

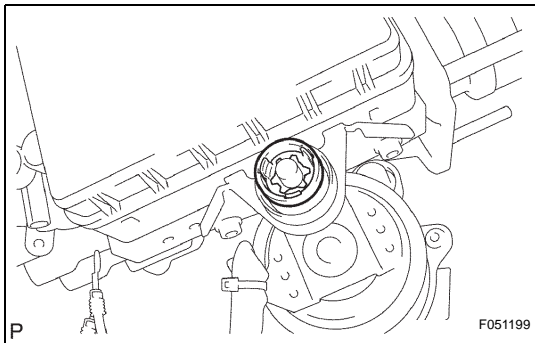

- (d) Install a new clip.

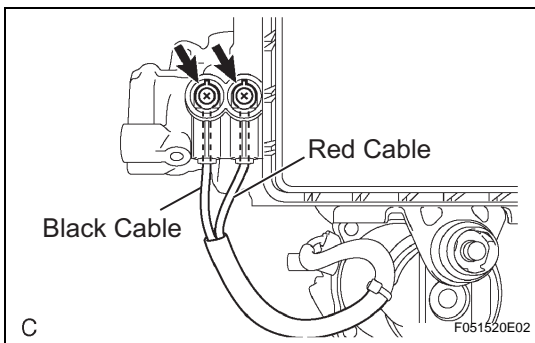

- (e) Install the wire harnesses with the 2 screws.
Torque: 2.9 N*m (30 kgf*cm, 26 in.*lbf)

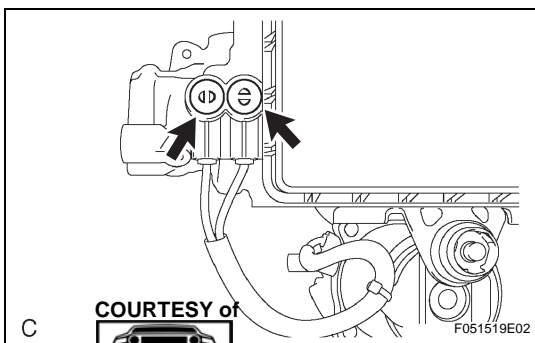

- (f) Install 2 new plugs.

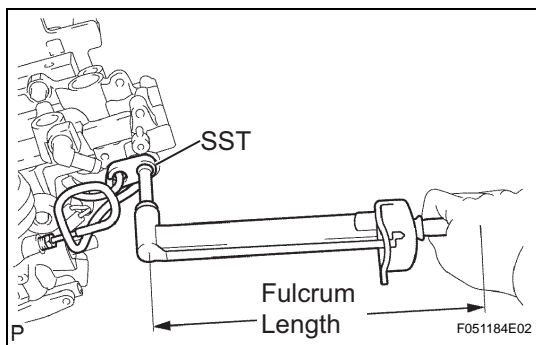

9. INSTALL BRAKE ACTUATOR NO. 1 TUBE

- (a) Using SST, install the brake actuator tube.

SST 09023-00101

Torque: for use without SST

15 N*m (155 kgf*cm, 11 ft.*lbf)

for use with SST

14 N*m (143 kgf*cm, 10 ft.*lbf)

HINT:

- Use a torque wrench with a fulcrum length of 300 mm (11.81 in.).
- This torque value is effective when SST is parallel to the torque wrench.

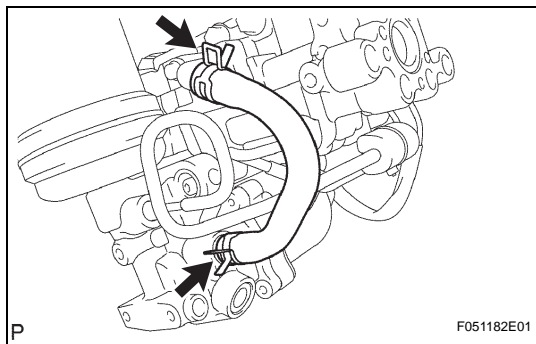

10. INSTALL BRAKE ACTUATOR HOSE

- (a) Using needle-nose pliers, install the brake actuator hose with the 2 clips.

11. INSTALL BRAKE MASTER CYLINDER RESERVOIR SUB-ASSEMBLY

- (a) Apply lithium soap base glycol grease to 3 new grommets.

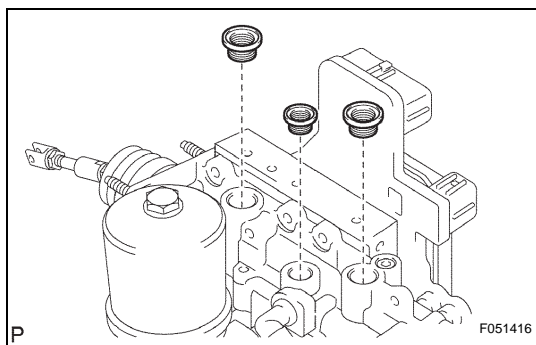

- (b) Install the 3 grommets onto the master cylinder body.

NOTICE:

The grommets are different sizes. Install the grommets in their correct positions.

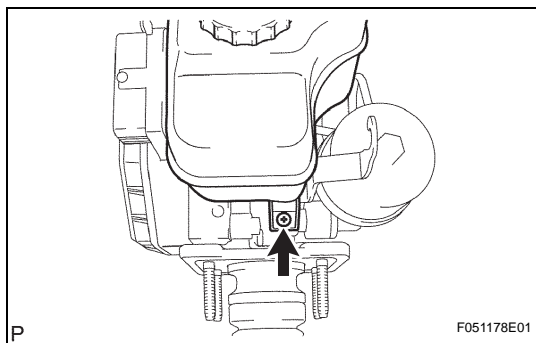

- (c) Install the master cylinder reservoir with the screw.
Torque: 1.7 N*m (17 kgf*cm, 15 in.*lbf)

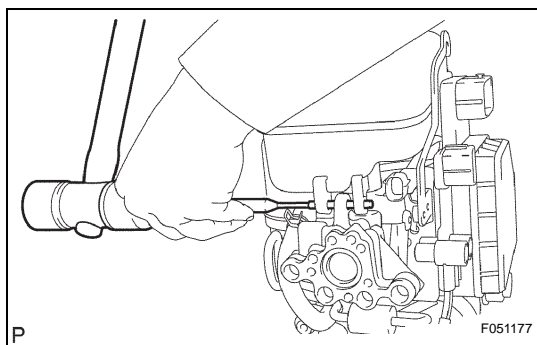

(d) Using a pin punch and hammer, install a new pin onto the master cylinder reservoir.

12. INSTALL BRAKE ACTUATOR NO. 1 BRACKET

(a) Install the fluid level warning switch connector.

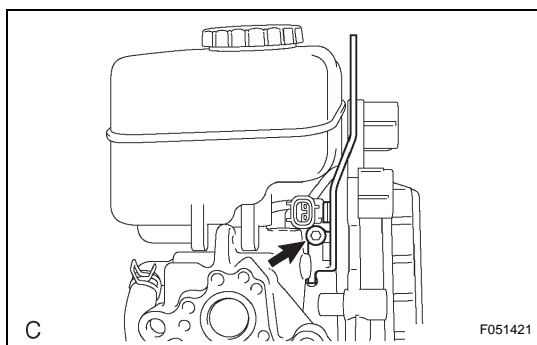

(b) Using a 5 mm hexagon wrench, install the brake actuator bracket with the bolt.

Torque: 7.8 N*m (80 kgf*cm, 69 in.*lbf)

BR