

REMOVAL

1. DISCONNECT CABLE FROM NEGATIVE BATTERY TERMINAL
2. REMOVE V-BANK COVER (See page [ES-428](#))
3. REMOVE NO.1 ENGINE UNDER COVER SUB-ASSEMBLY (See page [EM-6](#))
4. REMOVE RADIATOR SUPPORT SEAL UPPER (See page [CO-23](#))
5. REMOVE FAN SHROUD (See page [CO-23](#))
6. REMOVE FAN
 - (a) Remove the 4 nuts and the fan from the fluid coupling.

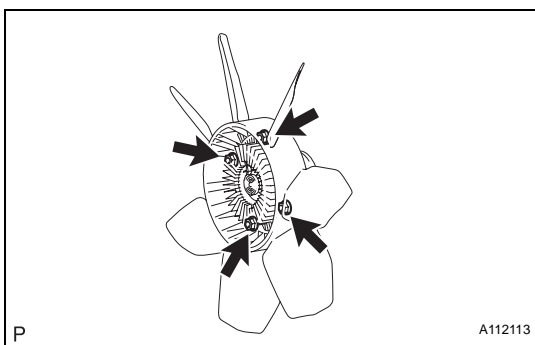
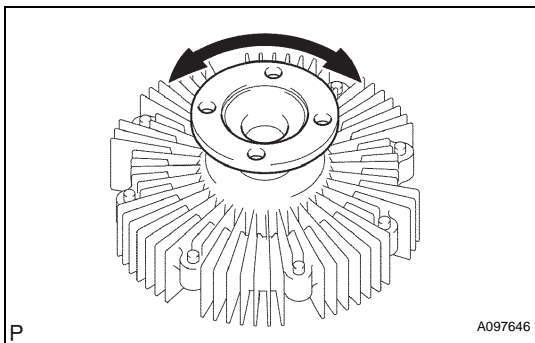
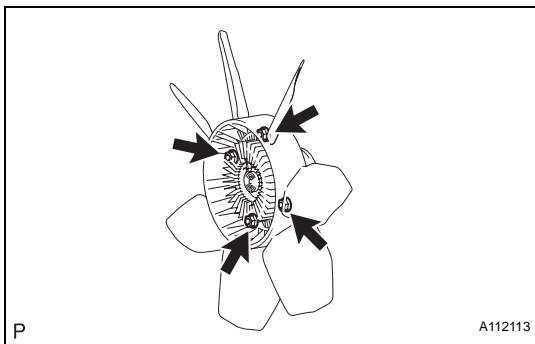

INSPECTION

1. INSPECT FLUID COUPLING ASSEMBLY
 - (a) Check the fluid coupling for damage and silicon oil leakage.
If necessary, replace the fluid coupling.

CO

INSTALLATION

1. INSTALL FAN
 - (a) Install the fan onto the coupling with the 4 nuts.
Torque: 9.0 N*m (92 kgf*cm, 80 in.*lbf)
2. INSTALL FAN SHROUD (See page [CO-30](#))
3. INSTALL RADIATOR SUPPORT SEAL UPPER (See page [CO-31](#))
4. INSTALL NO.1 ENGINE UNDER COVER SUB-ASSEMBLY (See page [EM-7](#))
5. INSTALL V-BANK COVER (See page [ES-431](#))
6. CONNECT CABLE TO NEGATIVE BATTERY TERMINAL
Torque: 3.9 N*m (40 kgf*cm, 35 ft.*lbf)